



Solar Wireless Parking Assistant

VAE 225

Installation & User Manual



VAE 225	V0	1111127	6AM0-00002
---------	----	---------	------------

Thank you for choosing **VISION Solar Wireless Parking Assistant VAE-225**.

VISION Solar Wireless Parking Assistant is environmentally friendly and practical, easy to install. It uses ultrasonic sensors to help you judge how close you are to the obstacles. It provides a visual and audible alarm when close to large obstacles to aid the driver while parking.

Its unique feature with solar power design, there is no need to replace sensor battery. We also design wireless transmission, it allows our product for quick installation without additional cable. Solar Wireless Parking Assistant is the most convenient for parking.

Please read the installation & user manual carefully before using the product. Improper installation will void warranty of the manufacturer. The installation & user manual is not applicable to all types of vehicles. Please pay attention to all of the precautions and instructions listed in this instructions.

Table of Contents

1.	Part List	P. 3
2.	Features	P. 5
3.	Specifications	P. 5
4.	Pre-Setting	P. 6
5.	Pairing of Sensor & Display	P. 6
6.	System Setting	P. 8
7.	Installation Guide	P. 8
8.	Detection & Alarm	P. 11
9.	Limitations	P. 12
10.	Trouble Shooting	P. 13

1. **Part List**

- **Display *1pcs**

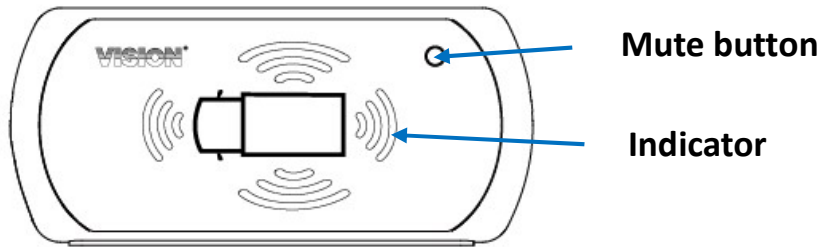

- **Solar Powered Parking Sensor * 2pcs**

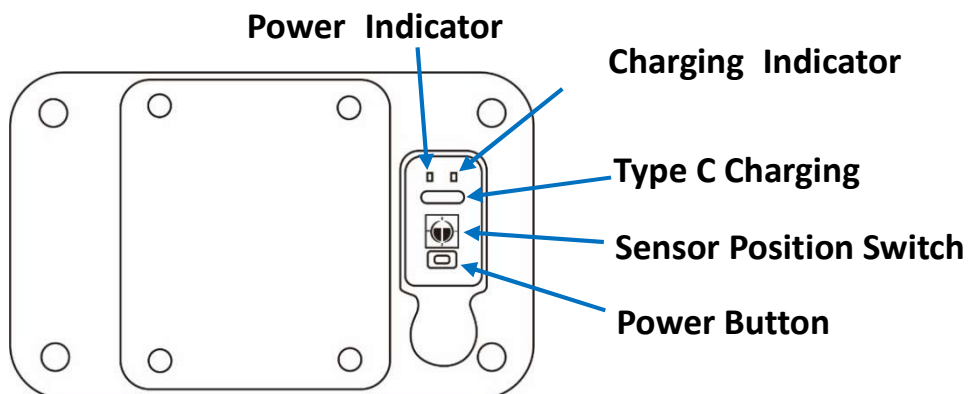
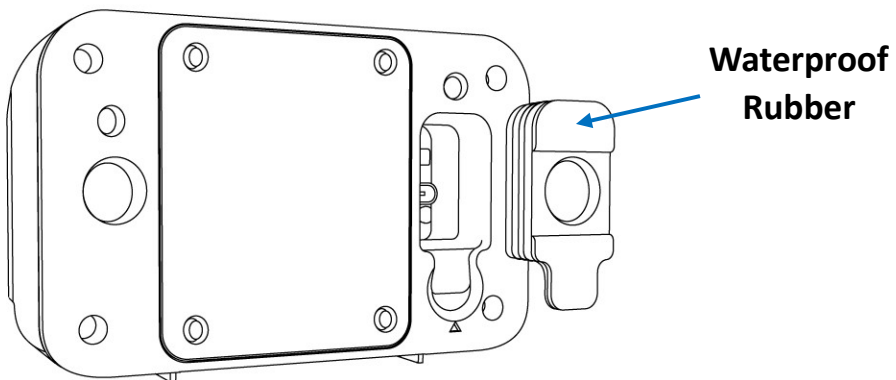
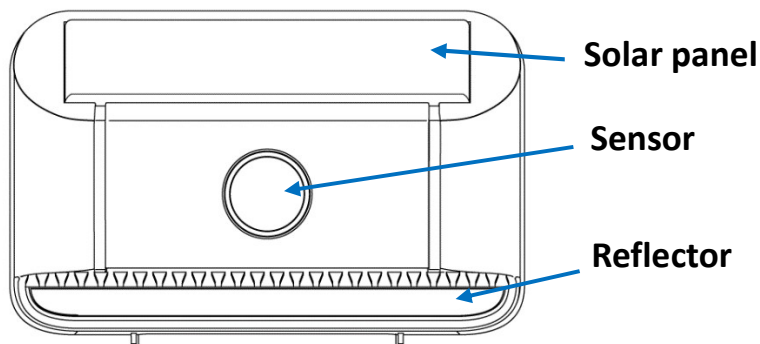

- **Metal Plate for Sensor *2pcs**

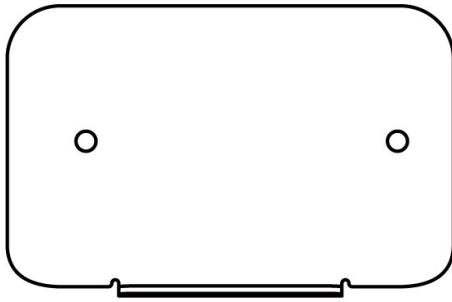

- **Screws for Metal Plate *4pcs**



- **Display Bracket *1pcs**

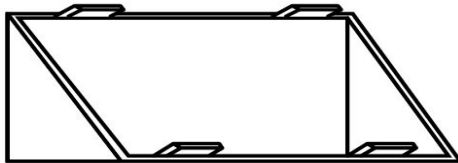

- **Large Double-sided tape (Display/Display Bracket) *1pcs**



- **Small Double-sided tape for Display *1pcs**

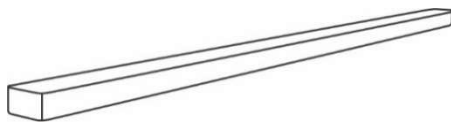

- **USB/Type C cable *1pcs**

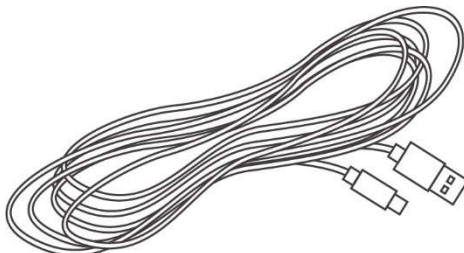

2. Features

- I. Easy to Install :
 - Magnetic mount
 - No drilling & No wiring
- II. Solar Powered :
 - The Sensor is rechargeable through natural daylight. Provide reliable & self-sustained power by solar light panel, no replacing battery.
- III. Power Saving :
 - The Sensor will be in standby mode while vehicle is stationary.

3. Specifications

● Sensor :

No	Item	Specifications
1	Water Resistance	IP67
2	Operation power	Solar power/Backup battery
3	Backup battery charging	Solar power/USB TYPE C
4	RF working frequency	433.92MHz
5	Operating temperature	-20°C ~ +70°C
6	Storage temperature	-40°C ~ +85°C
7	Vibration resistance	ISO 16750-3
8	Weight	260g

● Display :

No	Item	Specifications
1	Operation power	USB TYPE C
2	Operating temperature	-20°C ~ +70°C
3	Storage temperature	-40°C ~ +85°C
4	Standby Current	< 5 mA
5	Buzzer	85dB min (at 10cm)
6	Weight	52g

4. **Pre-Setting**

Sensor

- Please make sure the Sensor is charged with type C or Solar power charging before using it. Even the Sensor is not fully charged, the Sensor still can work normally. Please remove cable when you find the Charging Indicator from lighting status turning OFF.
- To put back sensor's waterproof rubber when sensor charging is done.
- Make sure that the vehicle installation location is compatible with magnetic material. Sensor requires a flat area for better magnetic mounting. If it is not compatible with magnetic material, please screw metal bracket for magnetic mounting.

Display

- Please make sure that the vehicle has USB socket for Display installation.
- Plug USB Type C to display charging slot.
- Find the proper display installation method on vehicle.

5. **Pairing of Sensor & Display**

- Pairing of Sensor & Display :
 - I. Before pairing, please make sure Sensor is power OFF and Display is power ON status. The distance between Sensor and Display needs to be within 30cm to be paired.
 - II. Adjust Sensor Position Switch to the expected installation position and remark it on rear Sensor label.
 - III. Press Sensor power button 4 times within 2 seconds, the Display will flash 2 times quickly with beep sound. It means the pairing process is successful.
 - IV. Follow step II and III for pairing other Sensors, able to support 8 Sensors at the same time.
 - V. The maximum for sensor pairing is 8pcs, if user want to pair the 9th Sensor, the Display will flash 4 times with beep sound 4 times, which means the pairing process is failed.

- Clear Sensor Pairing:

Press Display Mute Button 3 times, after hearing the beep sound, then press and hold the Display Mute button for 5 seconds within 3 seconds to clear all pairing.

The Display will quick flash while the clear Sensor pairing process is successfully.

● Sensor Position Switch Instruction :

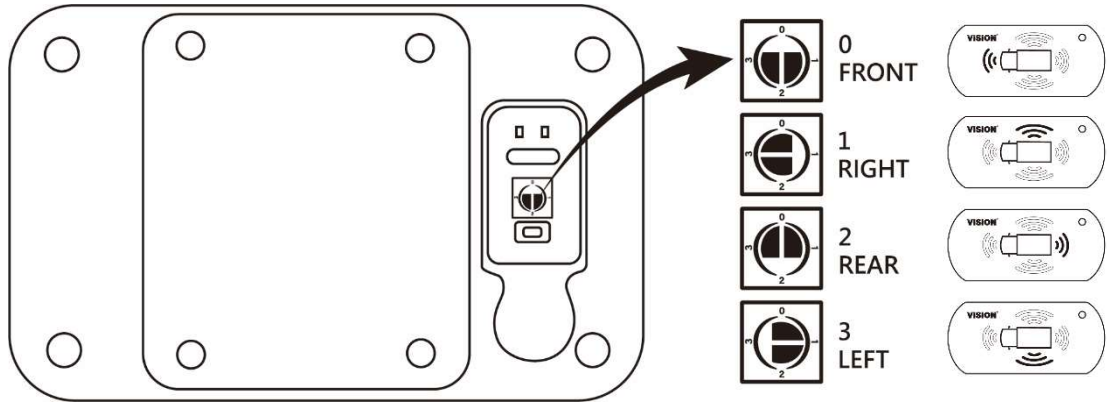

Note: 1 Display can be paired with 1 to 8 sensors.

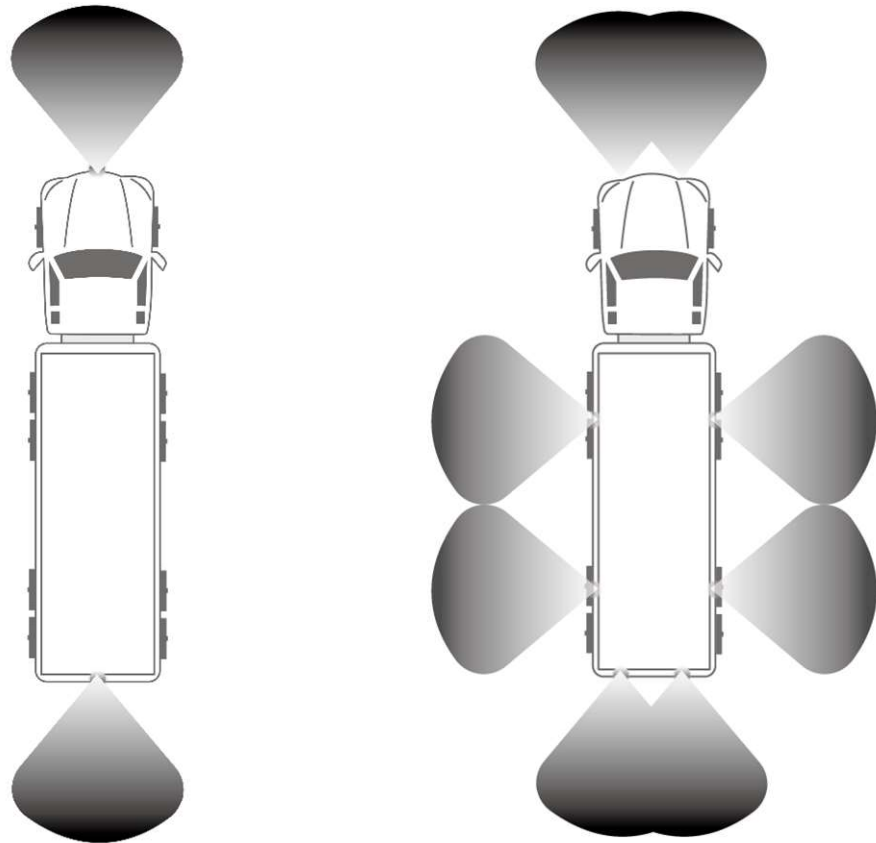

6. System Setting

Before use, we recommend fully charging the Sensor battery.

- Power on the sensors to start to use:
 - I. Please take out waterproof rubber.
 - II. Use tool to press and hold sensor power button for more than 1 second, the Power Indicator will turn on “Red” for starting working.
 - III. After turn on Sensor, please put back waterproof rubber.
 - IV. Find the proper installation location on vehicle, please refer to “Installation Guide”.
 - V. After Sensor is installed on vehicle, please stand back from Sensor for testing first to make sure the sensor detection function is ok.
- If you need to install Left/Right sensor, please make sure the Front/Rear sensor also install on vehicle at the same time.
- Display Mute :
 - I. In normal mode : Press the Mute button for 1 second to activate Display silent mode.
 - II. In silent mode : Press the Mute button for 1 second to inactivate Display silent mode
- Sensor power saving mode:

When the car is not moving, the Sensor enters a dormant state automatically to save power
- Battery :
 - I. The power of the Sensor can be used continuously with sufficient sunlight.
 - II. The power of the Sensor can be used continuously more than 24 hours without sufficient sunlight.
 - III. When battery at low voltage state, the display will flash 2 times/Sec until sensor battery re-charge completed; if the battery voltage run out off power, the system will shuts down.
- If sensor missing, display did not receive the paired sensor signal, the LED at the corresponding position of the Display will flash 4 times/SEC continuously, and the Buzzer will beep 4 times intermittently per second for 60 seconds.

7. Installation Guide

Before use, we recommend fully charging the Sensor battery.

● Sensor installation

The sensor can be installed both on vehicle with magnetic compatible car body or not magnetic compatible car body.

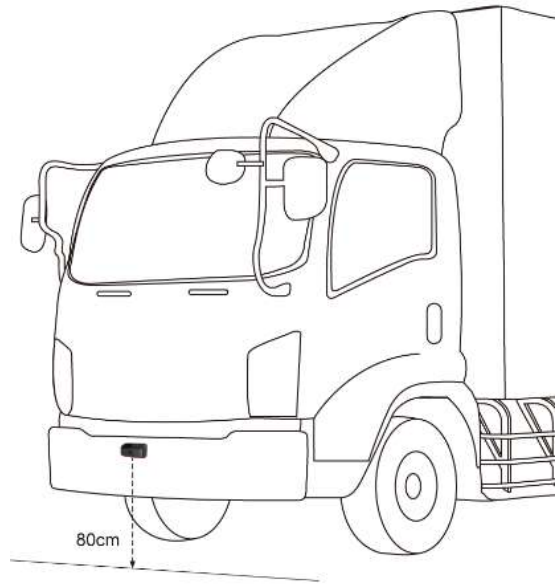
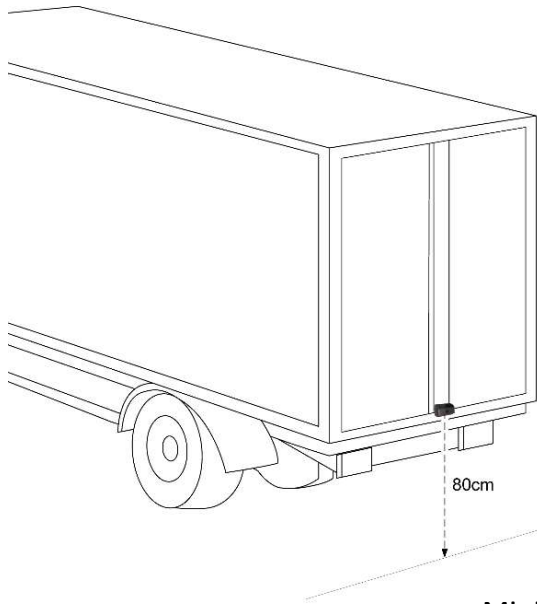

Minimum height
from the ground

Condition 1:
Solar Powered Parking Sensor
uses magnets to be directly
attached to the magnetic
compatible car body.

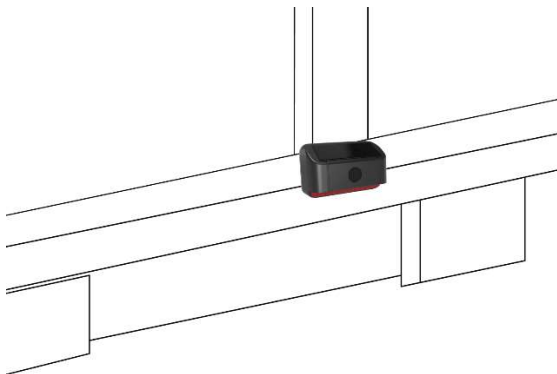

Condition 2:
For not magnetic compatible car
body, the metal plate needs to be
locked with screws on the car
body first, and then the Solar
Powered Parking Sensor can be
attached to the metal plate.

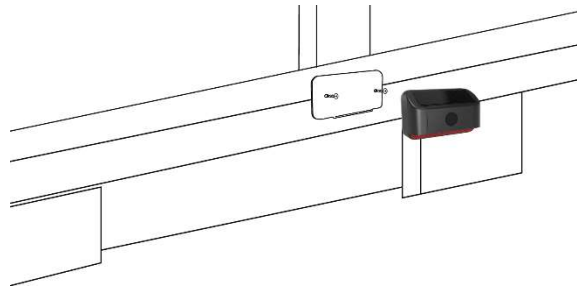

Please make sure the surface is flat before attaching the sensors.

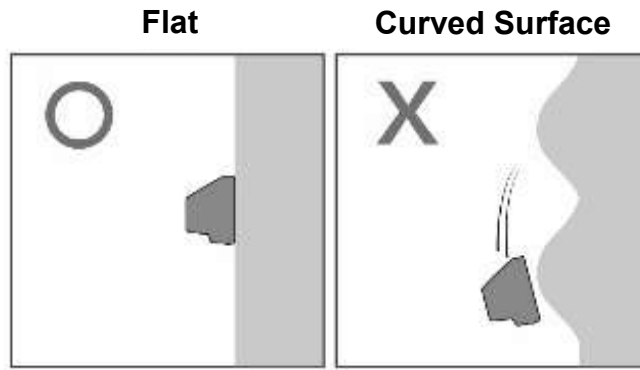

Remark:

If you need to install 2 sensors on the same side, the suggested minimum distance between sensors is 80cm.

● Display installation

We provide 3 methods for display installation, user can find the proper location for display installation on vehicle dashboard or on windshiled :

Option 1:

Paste the small double-sided tape on the bottom of the Display and fix it on the dashboard, or any location for better driver viewing.

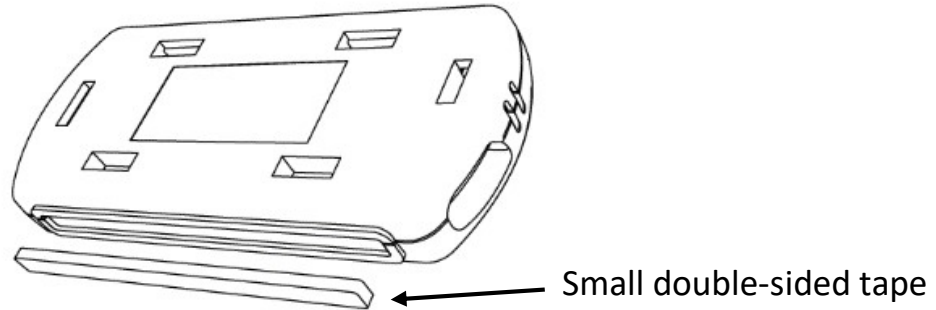

Option 2:

Paste the large double-sided tape on the bottom of the Display and fix it on the proper location for better driver viewing.

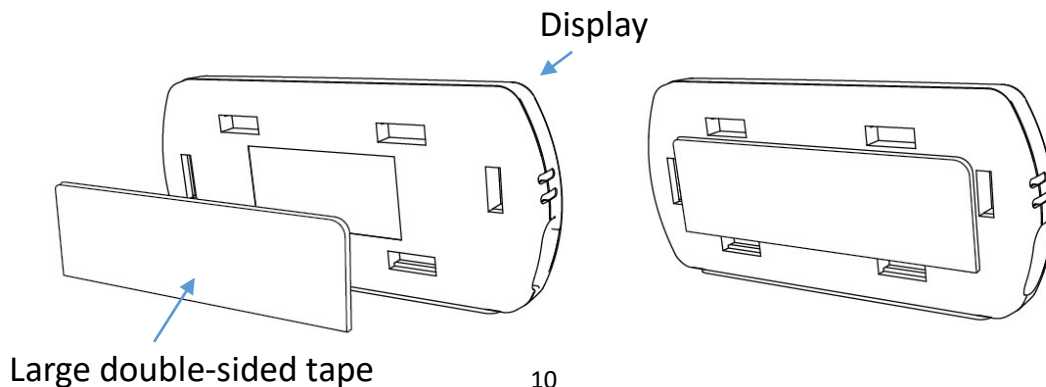

Option 3:

Install the Display Bracket into the back of the Display, and stick the large double-sided tape on the Display bracket. Then, fix it on proper location for better driver viewing.

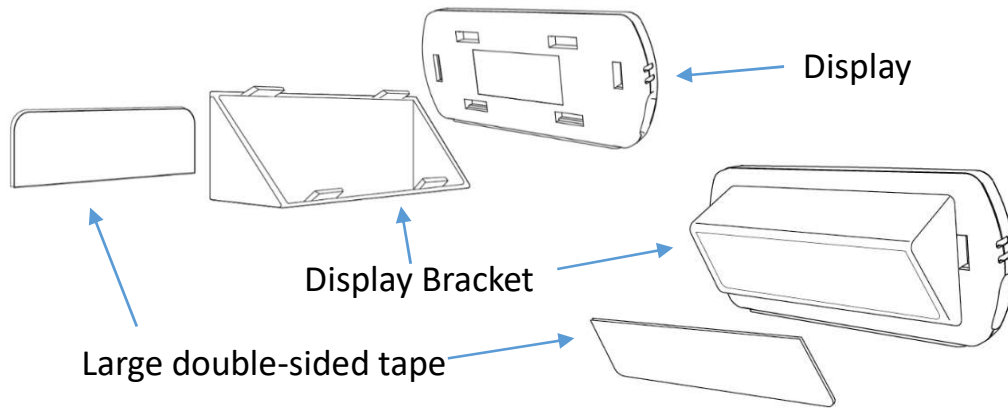

8. Detection & Alarm

The detection alarm according to different distance.

Side sensors with Front or Rear Sensors

Item	Detection Range	Display LED Indicator	Alarm	Remark
Rear Sensor	200cm	>50~200cm : Light up	≤50cm : Constant Beep 50cm ~ 100cm : Beep.Beep...	The alarm will be off after 30 seconds for the same obstacles.
Front Sensor		≤50cm : Light Flashes	100cm ~ 200cm : Beep...Beep... > 200cm : OFF	
Right Sensor		≤100cm : Light up	≤60cm : Beep.Beep__Beep.Beep	
Left Sensor			> 60cm : OFF	

*Remark:

The system focus on car parking assistant.

If you need to detect both side area while driving, please make sure that the front or rear sensor MUST installed on vehicle as well.

9. Limitations

The sensors may not work correctly if an object does not reflect the ultrasonic waves or it has an unusual shape e.g. poles/bollards, cardboard cartons, motorcycle/bicycle tires, small or slender trees.

Please see examples below:

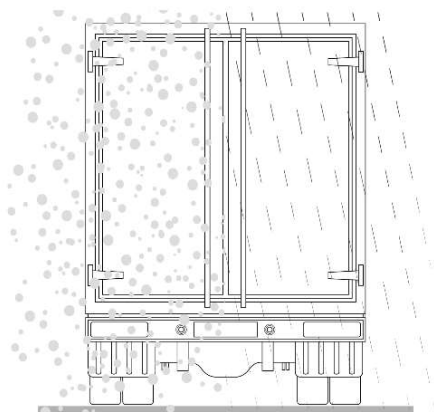

If there is a heavy rain or snow

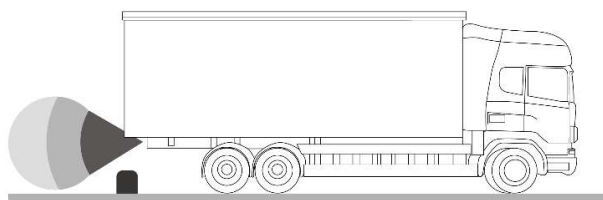

If there is a very small object

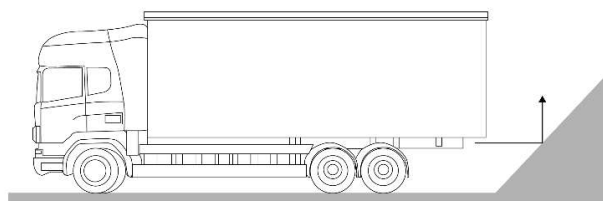

If there is a smooth slope

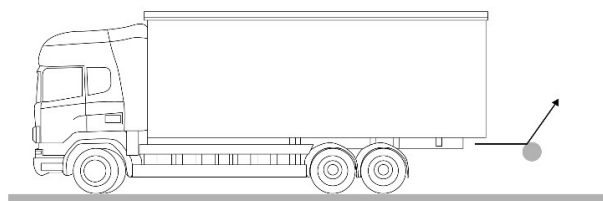

If there is a smooth round object

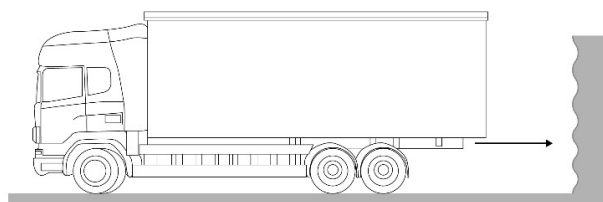

If there is a objects absorbing wave

10. Trouble Shooting & Notice

- I. If you require mute function, please press Mute button on Display
- II. Under paired status, if the Display flash quickly with beep sound, it means the bad detection signal or the signal is interfered.
Please adjust the display to a higher position and away from metal part.
- III. Under paired status, if the Display keeps quick flash continuously with sound, it means the Sensor might be missing. Please check and clean all pairing status and then the Display can back to normal situation.
Please contact the nearest distributor to solve this issue.

It is the driver's responsibility to maintain safe reverse parking skills, such as slowing down, use of rear and side mirrors are always essential.

Please remove water, snow or mud on the sensors in time.